

Austin Series SMT Non-Isolated dc-dc Power Modules: 3.0 Vdc - 5.5 Vdc Input, 1.5 Vdc - 3.3 Vdc Output, 6 A

RoHS Compliant



Applications

- Workstations, Servers and Desktop computers
- Distributed Power Architectures
- Telecommunications Equipment
- DSP applications
- LANs/WANs
- Data processing Equipment
- Adapter cards.

Description

The Austin Power Module Series is designed to meet the precise voltage and fast transient requirements of today's high performance DSP and microprocessor circuits and system board level applications. Advanced circuit techniques, high frequency switching, custom passive and active components, and very high density, surface-mount packaging technology deliver high quality, ultra compact, DC-DC conversion.

Features

- Compatible with RoHS EU Directive 200295/EC (-Z versions)
- Compatible with RoHS EU Directive 200295/EC with lead solder exemption (non -Z versions)
- 300A/ μ s load transient response
- High efficiency:
 - 3.3 VIN
 - 86% typical @ 2.5V,6A
 - 74% typical @ 1.5V,6A
 - 5 VIN
 - 85% typical @ 3.3V,6A
 - 73% typical @ 1.8V,6A
- Small size and very low profile:
 - 44.6 mm x 12.7 mm x 5.46 mm
 - (1.756 in x 0.50 in x 0.214 in)
- High reliability: 200 FITs/5 million hour MTBF
- Single control pin for margining and on/off control
- Overcurrent foldback
- Thermal shutdown
- No External Bias required
- Low Inductance surface mount connections
- Parallelable
- UL* 60950 Recognized, CSA† C22.2 No. 60950-00 Certified, and VDE‡ 0805 (IEC60950, 3rd edition) Licensed

* UL is a registered trademark of Underwriters Laboratories, Inc.

† CSA is a registered trademark of Canadian Standards Association.

‡ VDE is a trademark of Verband Deutscher Elektrotechniker e.V.

§ This product is intended for integration into end-use equipment. All the required procedures for CE marking of end-use equipment should be followed. (The CE mark is placed on selected products.)

** ISO is a registered trademark of the International Organization of Standards

Absolute Maximum Ratings

Stresses in excess of the absolute maximum ratings can cause permanent damage to the device. These are absolute stress ratings only, functional operation of the device is not implied at these or any other conditions in excess of those given in the operations sections of the data sheet. Exposure to absolute maximum ratings for extended periods can adversely affect the device reliability.

Parameter	Device	Symbol	Min	Max	Unit
Input Voltage:Continuous	3.3 VIN	VIN	-0.3	4.5	Vdc
	5.0 VIN	VIN	-0.3	6.5	Vdc
Forced Output Voltage	All	VOF	-0.3	6.0	Vdc
OUTEN/ADJ Terminal Voltage	All	VOUTEN/ADJ	- 0.3	2.0	Vdc
Operating Ambient Temperature (See Thermal Considerations section)	All	TA	-40	80	°C
Storage Temperature	All	Tstg	-40	125	°C

Electrical Specifications

Unless otherwise indicated, specifications apply over all operating input voltage, resistive load, and temperature conditions.

Parameter	Device	Symbol	Min	Typ	Max	Unit
Operating Input Voltage	3.3 VIN	VIN	3.0	3.3	3.6	Vdc
	5.0 VIN	VIN	4.5	5.0	5.5	Vdc
Input Ripple Rejection (120 Hz)				50		dB
Operating Input Current (0A ≤ IOU T < 5A) (3.0 V < VIN < 3.6V) (4.5V < VIN < 5.5V)	3.3 VIN	IIN	—	—	5.5	A
	5.0 VIN	IIN	—	—	5.0	A
Quiescent Input Current (IOU T = 0) (3.0V < VIN < 5.5V)	All	IQ	—	15	—	mA

CAUTION: This power module is not internally fused. An input line fuse must always be used.

This power module can be used in a wide variety of applications, ranging from simple stand-alone operation to an integrated part of a sophisticated power architecture. To preserve maximum flexibility, internal fusing is not included; however, to achieve maximum safety and system protection, always use an input line fuse. The safety agencies require a normal blow fuse with a maximum rating of 10A (see Safety and Reliability Specifications).

Electrical Specifications (continued)

Parameter	Device	Symbol	Min	Typ	Max	Unit
Output Voltage (Over all operating input voltage, resistive load, and temperature conditions at steady state until end of life.)	3.3V	VOUT	3.2	3.3	3.4	Vdc
	2.5V	VOUT	2.425	2.5	2.575	Vdc
	2.0V	VOUT	1.940	2.0	2.060	Vdc
	1.8V	VOUT	1.746	1.8	1.854	Vdc
	1.5V	VOUT	1.455	1.5	1.545	Vdc
Output Ripple and Noise	3.3VIN	V _{RIPPLE}	—	—	80	mVp-p
	5.0VIN	V _{RIPPLE}	—	—	100	mVp-p
Output Current		IOUT	0	—	6.0	Adc

Characteristic Curves

The following figures provide typical characteristics curves at room temperature ($T_A = 25^\circ\text{C}$).

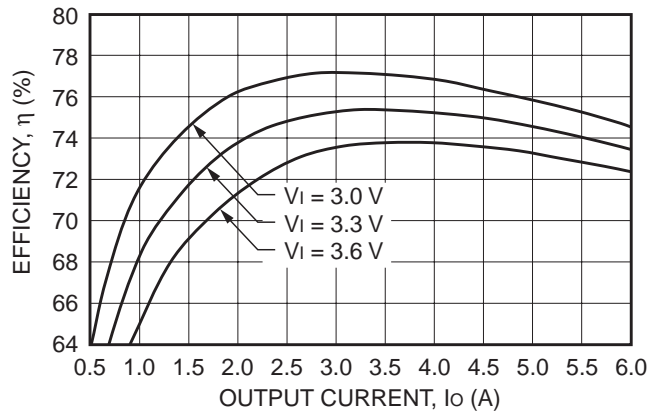

Figure 1. Converter Efficiency vs output current at 3.3VIN, 1.5VOUT.

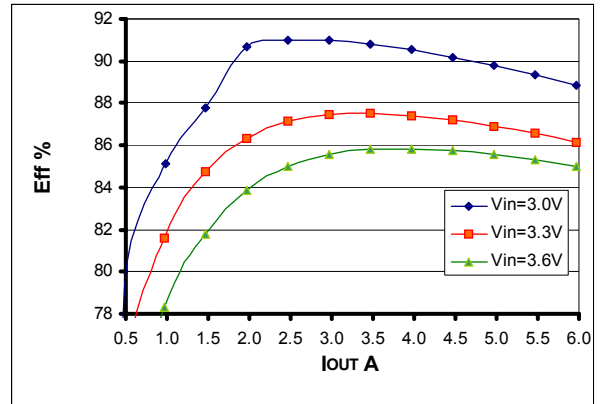

Figure 4. Converter Efficiency vs output current at 3.3VIN, 2.5VOUT.

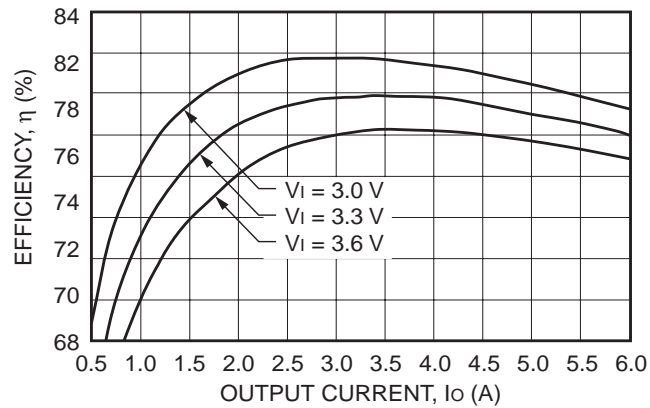

Figure 2. Converter Efficiency vs output current at 3.3VIN, 1.8VOUT.

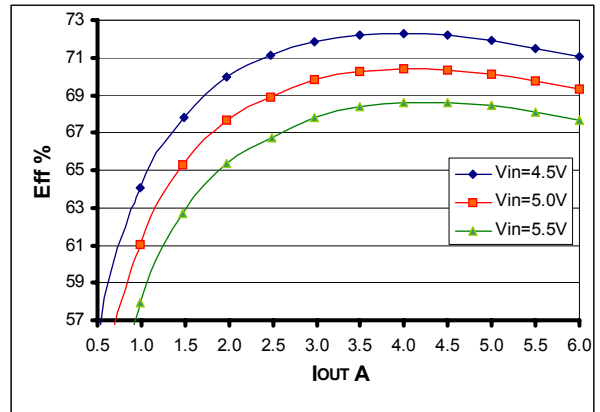

Figure 5. Converter Efficiency vs output current at 5.0VIN, 1.5VOUT.

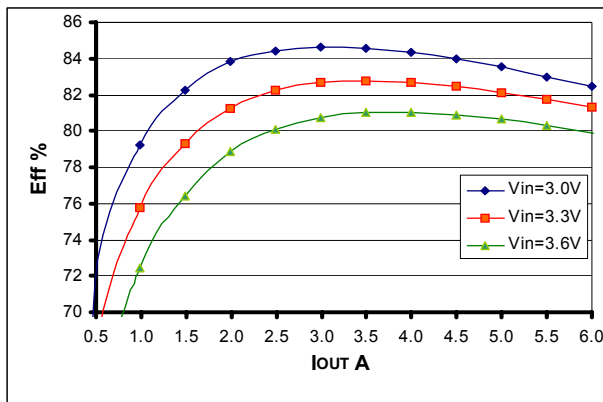

Figure 3. Converter Efficiency vs output current at 3.3VIN, 2.0VOUT.

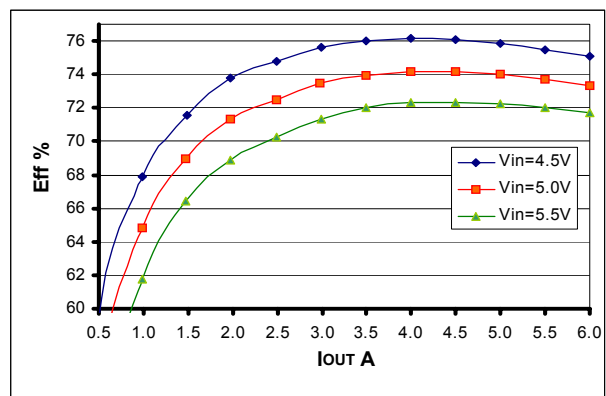

Figure 6. Converter Efficiency vs output current at 5.0VIN, 1.8VOUT.

Characteristic Curves

The following figures provide typical characteristics curves at room temperature ($T_A = 25\text{ }^\circ\text{C}$)

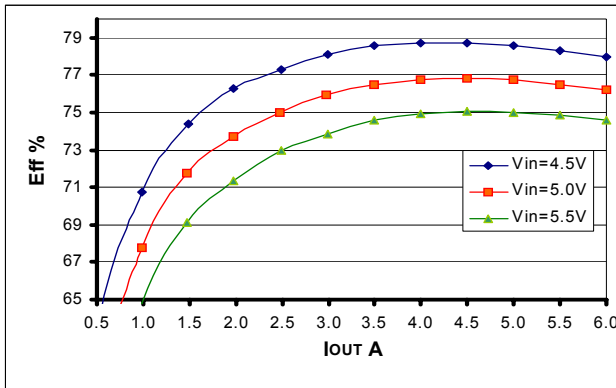

Figure 7. Converter Efficiency vs output current at 5.0VIN, 2.0VOUT.

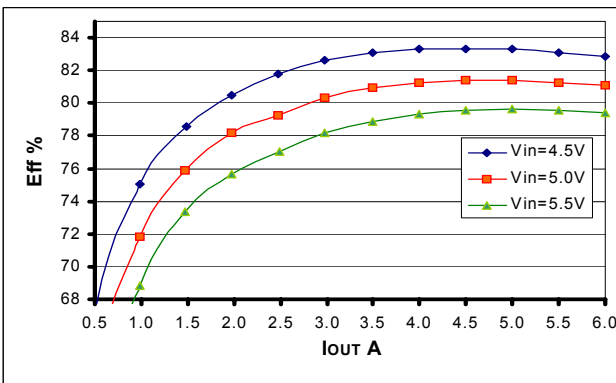

Figure 8. Converter Efficiency vs output current at 5.0VIN, 2.5VOUT.

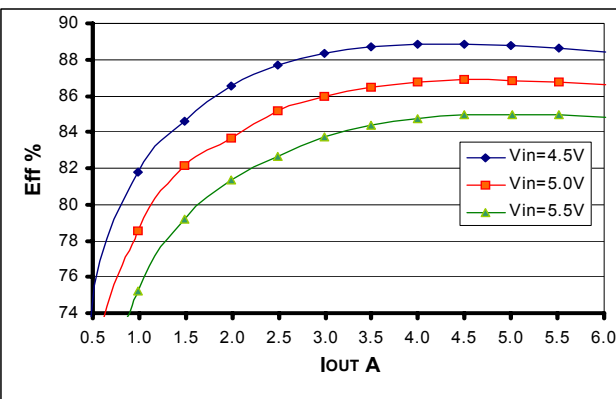

Figure 9. Converter Efficiency vs output current at 5.0VIN, 3.3VOUT.

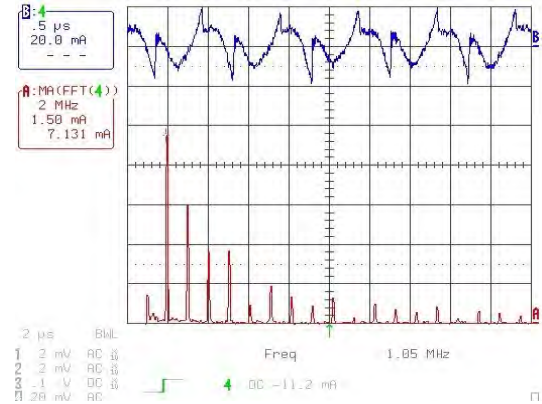

Figure 10. Typical Input Reflected Ripple current 5.0VIN, 1.5VOUT.

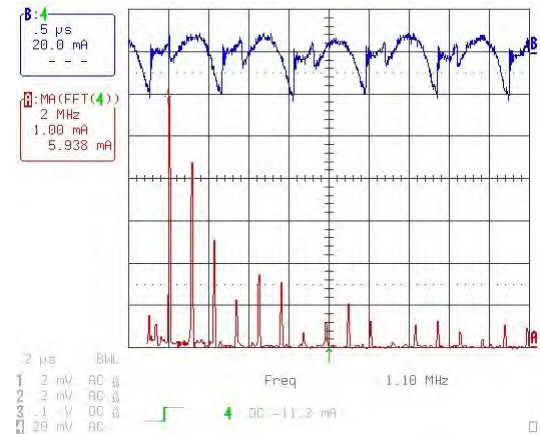

Figure 11. Typical Input Reflected Ripple current 5.0VIN, 3.3VOUT.

Characteristic Curves

The following figures provide typical Input/Output Ripple characteristics curves at room temperature (TA = 25 °C)

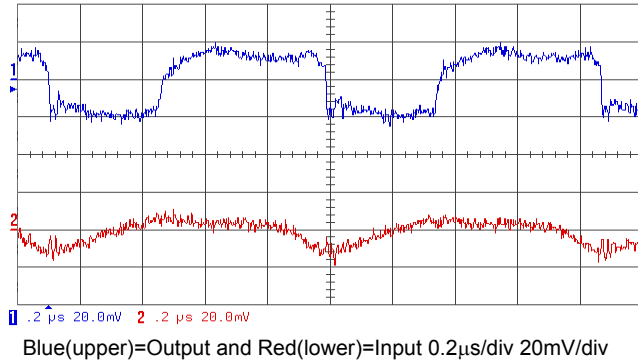

Figure 12. Typical Ripple Performance 3.3VIN,1.5VOUT.

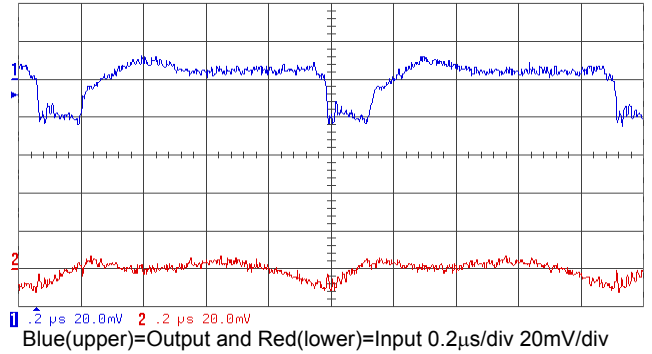

Figure 15. Typical Ripple Performance 3.3VIN,2.5VOUT.

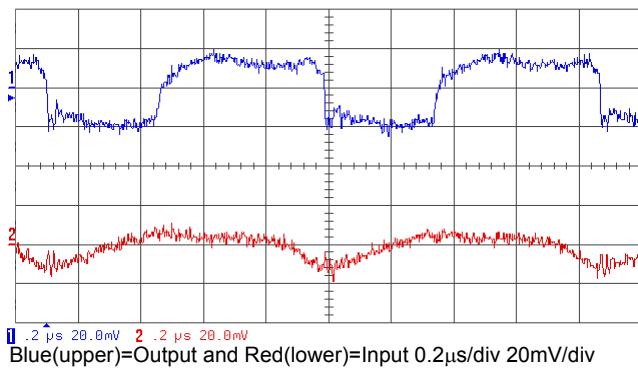

Figure 13. Typical Ripple Performance 3.3VIN,1.8VOUT.

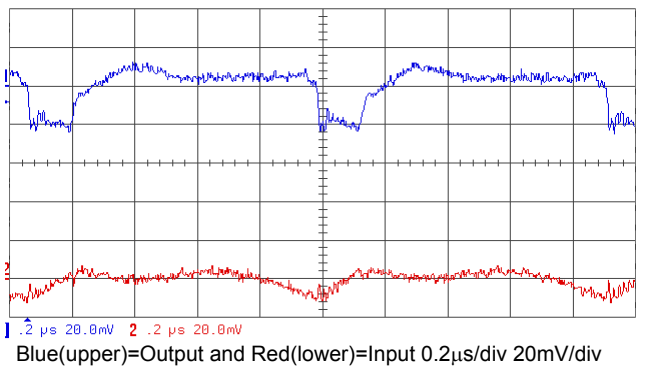

Figure 16. Typical Ripple Performance 5.0VIN,1.5VOUT.

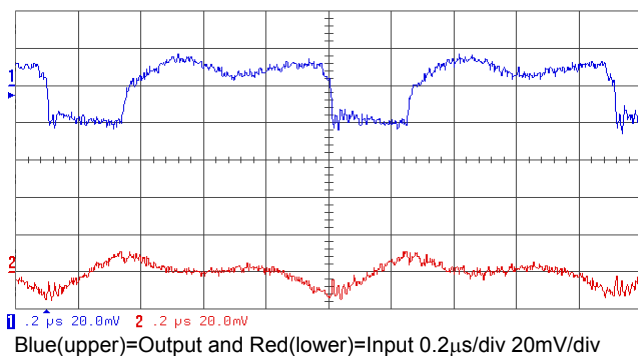

Figure 14. Typical Ripple Performance 3.3VIN,2.0VOUT.

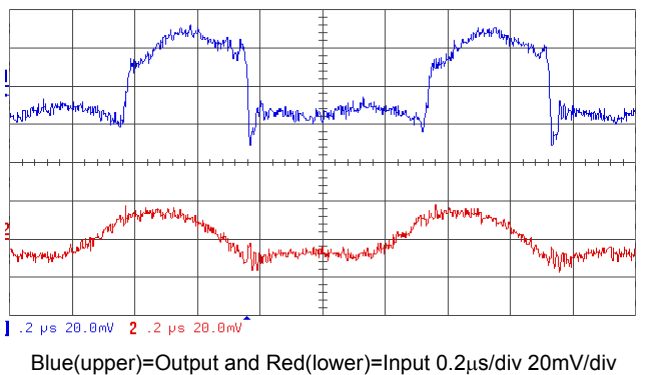

Figure 17. Typical Ripple Performance 5.0VIN,1.8VOUT.

Characteristic Curves

The following figures provide typical Input/Output Ripple characteristics curves at room temperature ($T_A = 25^\circ\text{C}$)

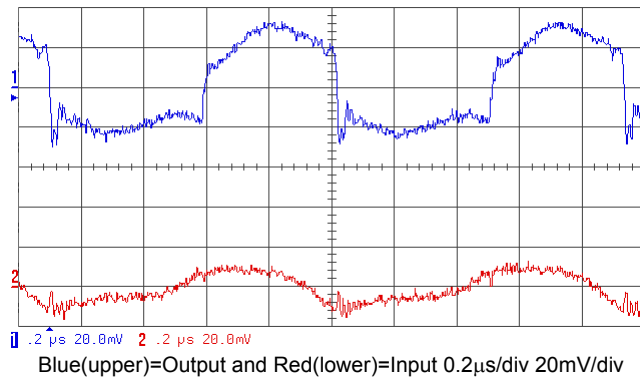

Figure 18. Typical Ripple Performance 5.0VIN,2.0VOUT.

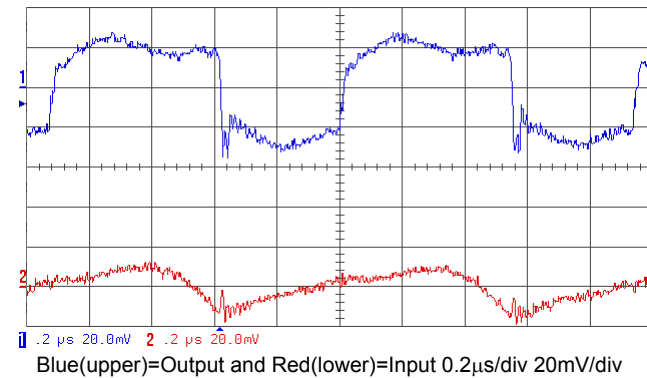

Figure 19. Typical Ripple Performance 5.0VIN,2.5VOUT.

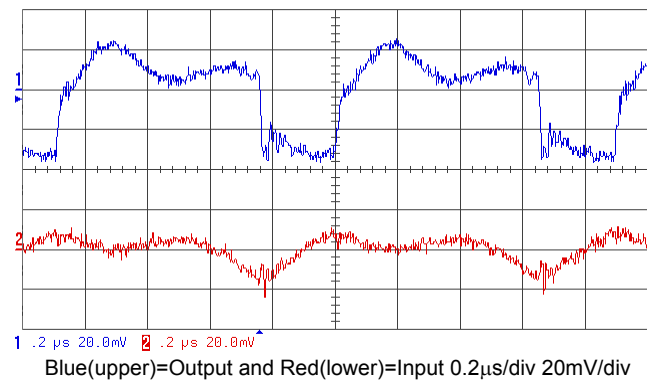

Figure 20. Typical Ripple Performance 5.0VIN,3.3VOUT.

Characteristic Curves

The following figures provide typical Start-up characteristics curves at room temperature ($T_A = 25^\circ\text{C}$)

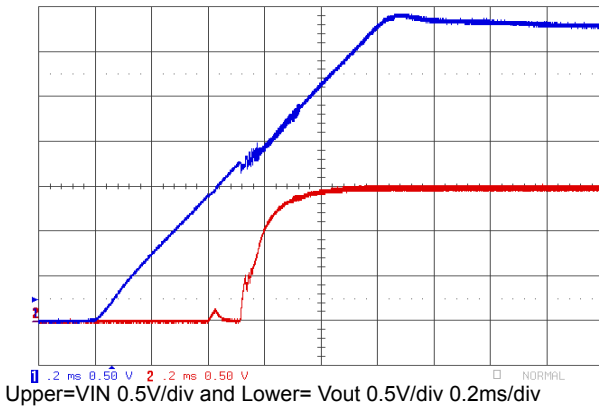

Figure 21. Input/Output Start-Up Characteristics :
3.3VIN,1.5VOUT,1ms input ramp.

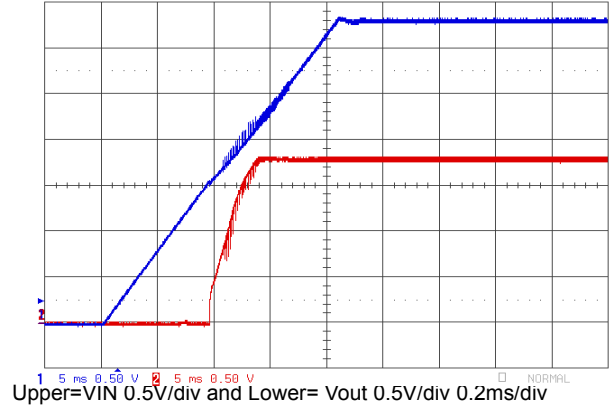

Figure 24. Input/Output Start-Up Characteristics :
3.3VIN,1.8VOUT,20ms input ramp.

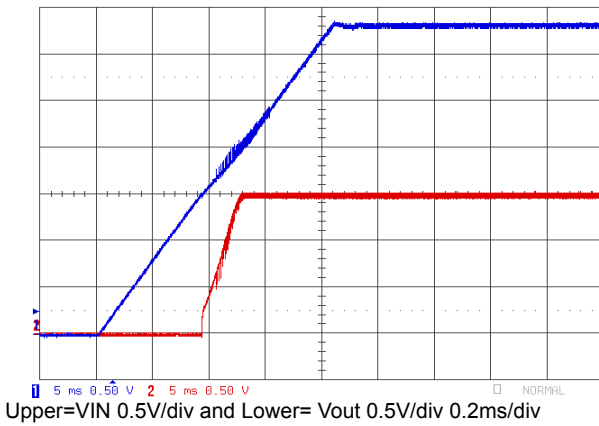

Figure 22. Input/Output Start-Up Characteristics :
3.3VIN,1.5VOUT,20ms input ramp.

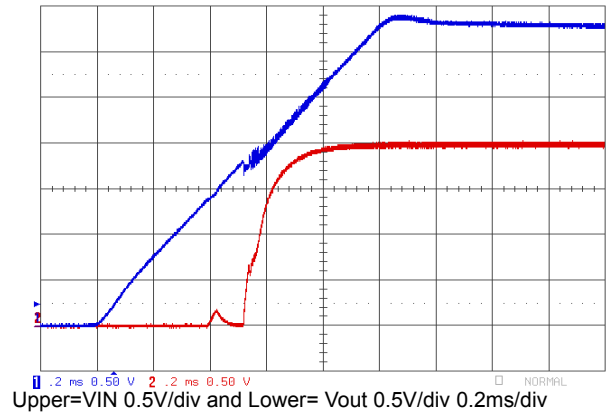

Figure 25. Input/Output Start-Up Characteristics :
3.3VIN,2.0VOUT,1ms input ramp.

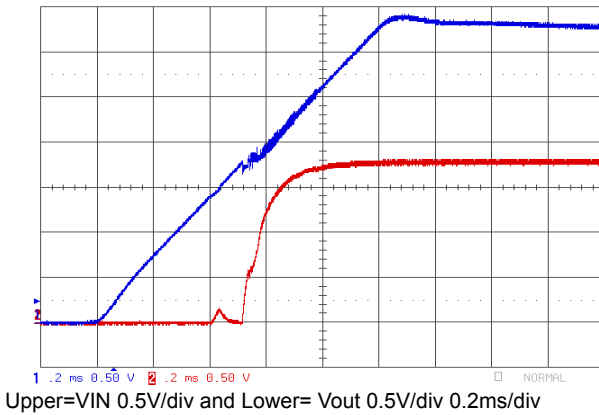

Figure 23. Input/Output Start-Up Characteristics :
3.3VIN,1.8VOUT,1ms input ramp.

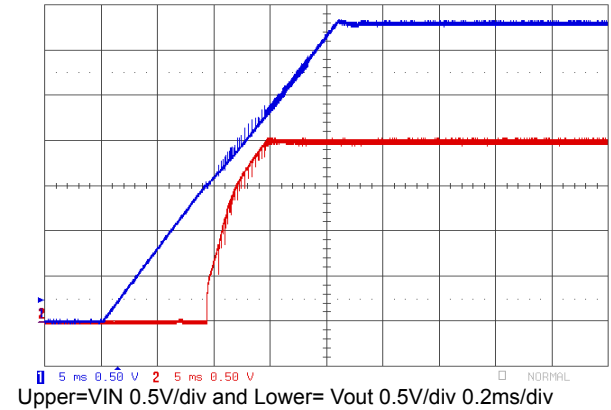
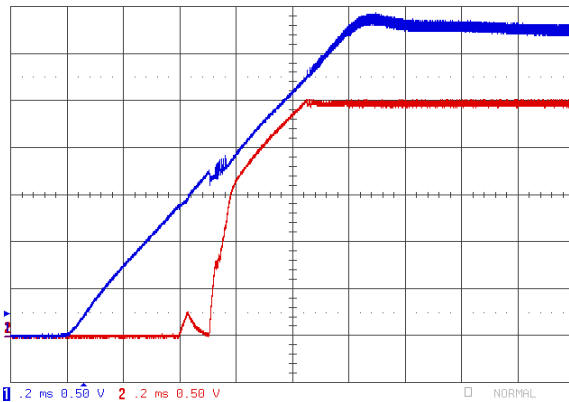

Figure 26. Input/Output Start-Up Characteristics :
3.3VIN,2.0VOUT,20ms input ramp.

Characteristic Curves

The following figures provide typical Start-up characteristics curves at room temperature ($T_A = 25^\circ\text{C}$)



Upper=VIN 0.5V/div and Lower= Vout 0.5V/div 0.2ms/div
**Figure 27. Input/Output Start-Up Characteristics :
 3.3VIN,2.5VOUT,1ms input ramp.**

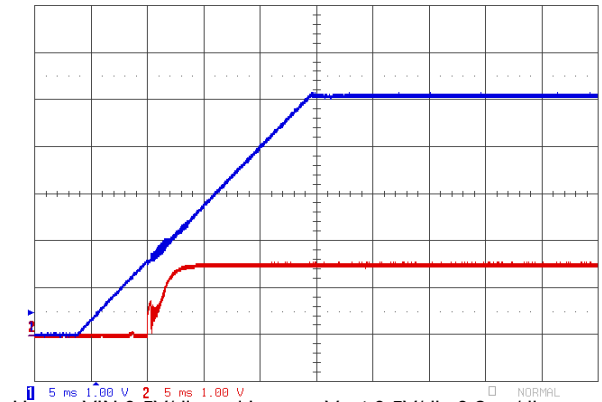

Upper=VIN 0.5V/div and Lower= Vout 0.5V/div 0.2ms/div
**Figure 30. Input/Output Start-Up Characteristics :
 5.0VIN,1.5VOUT,20ms input ramp.**

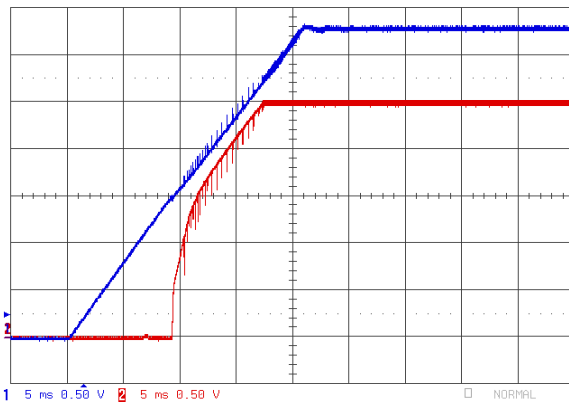

Upper=VIN 0.5V/div and Lower= Vout 0.5V/div 0.2ms/div
**Figure 28. Input/Output Start-Up Characteristics :
 3.3VIN,2.5VOUT,20 ms input ramp.**

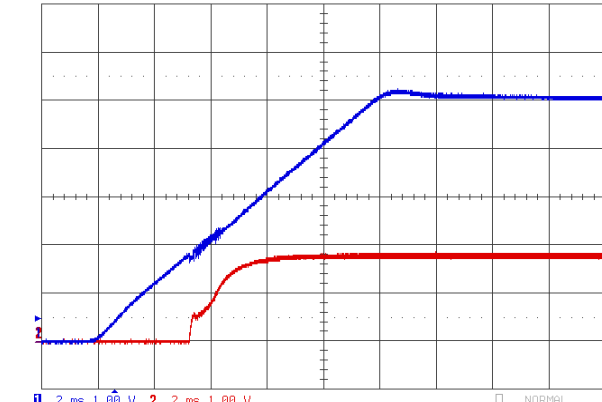

Upper=VIN 0.5V/div and Lower= Vout 0.5V/div 0.2ms/div
**Figure 31. Input/Output Start-Up Characteristics :
 5.0VIN,1.8VOUT,1ms input ramp.**

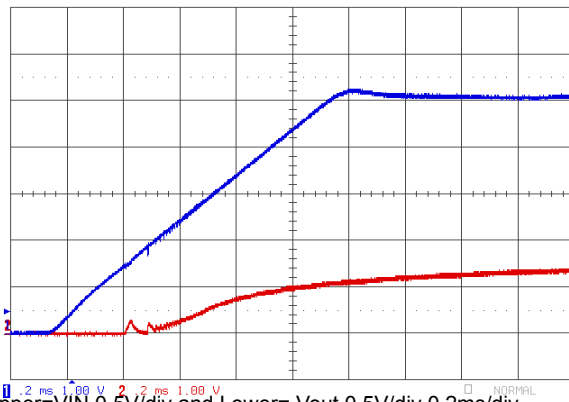

Upper=VIN 0.5V/div and Lower= Vout 0.5V/div 0.2ms/div
**Figure 29. Input/Output Start-Up Characteristics :
 5.0VIN,1.5VOUT,1ms input ramp.**

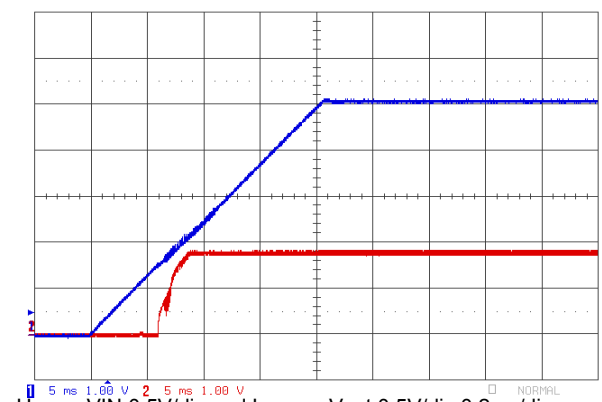

Upper=VIN 0.5V/div and Lower= Vout 0.5V/div 0.2ms/div
**Figure 32. Input/Output Start-Up Characteristics :
 5.0VIN,1.8VOUT,20ms input ramp.**

Characteristic Curves

The following figures provide typical Start-up characteristics curves at room temperature ($T_A = 25^\circ\text{C}$)

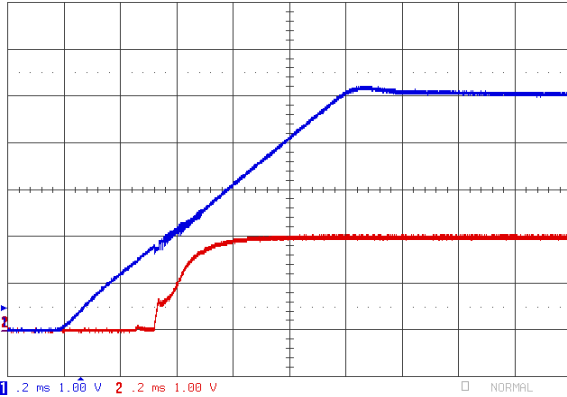

Upper=VIN 0.5V/div and Lower= Vout 0.5V/div 0.2ms/div

**Figure 33. Input/Output Start-Up Characteristics :
5.0VIN,2.0VOUT,1ms input ramp.**

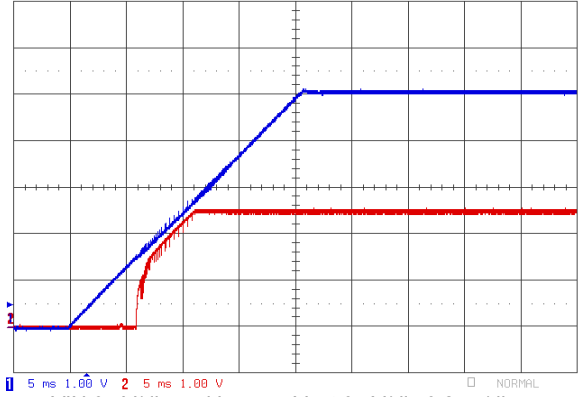

Upper=VIN 0.5V/div and Lower= Vout 0.5V/div 0.2ms/div

**Figure 36. Input/Output Start-Up Characteristics :
5.0VIN,2.5VOUT,20ms input ramp.**

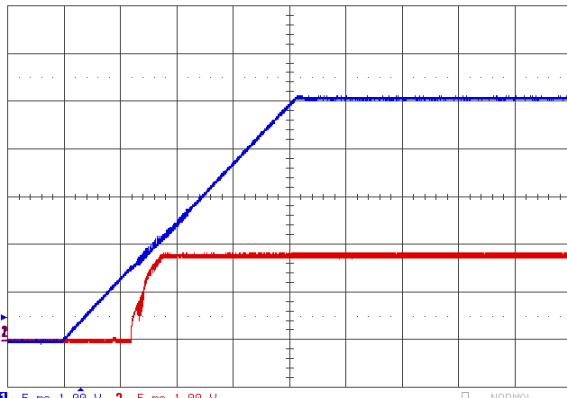

Upper=VIN 0.5V/div and Lower= Vout 0.5V/div 0.2ms/div

**Figure 34. Input/Output Start-Up Characteristics :
5.0VIN,2.0VOUT,20ms input ramp.**

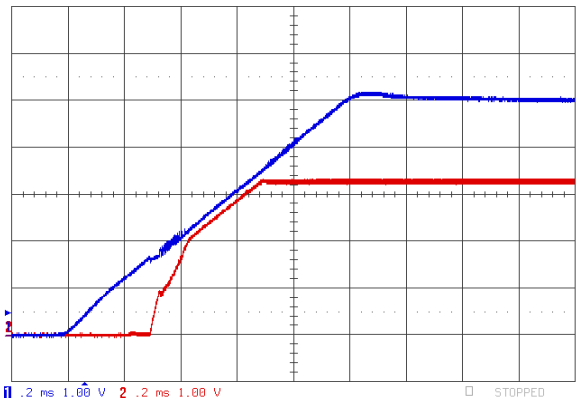

Upper=VIN 0.5V/div and Lower= Vout 0.5V/div 0.2ms/div

**Figure 37. Input/Output Start-Up Characteristics :
5.0VIN,3.3VOUT,1ms input ramp.**

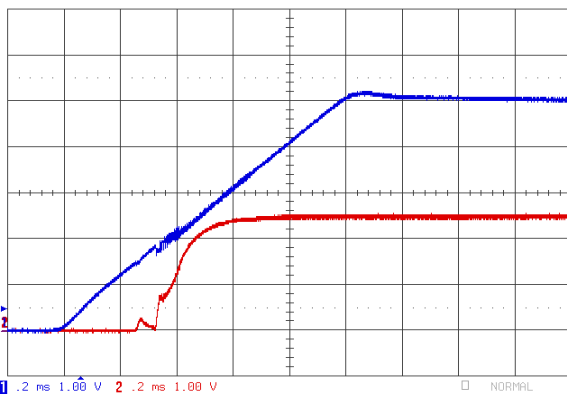

Upper=VIN 0.5V/div and Lower= Vout 0.5V/div 0.2ms/div

**Figure 35. Input/Output Start-Up Characteristics :
5.0VIN,2.5VOUT,1ms input ramp.**

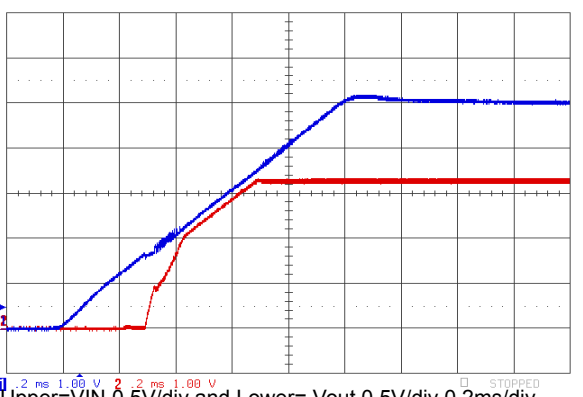

Upper=VIN 0.5V/div and Lower= Vout 0.5V/div 0.2ms/div

**Figure 38. Input/Output Start-Up Characteristics :
5.0VIN,3.3VOUT,20ms input ramp.**

Characteristic Curves

The following figures provide typical Transient response characteristics curves at room temperature (TA = 25 °C)

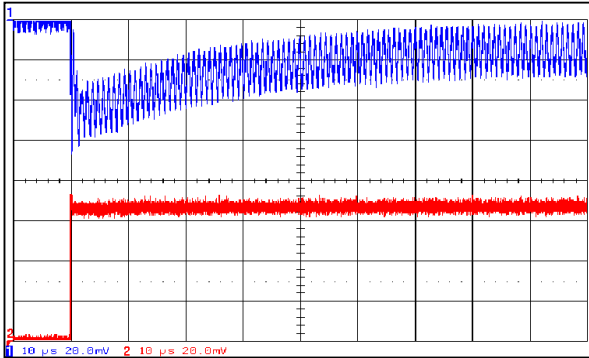

Blue(upper)=Vout 20mV/div Red(lower)=1A/div 10µs/div

Figure 39. Typical Transient response: 3.3VIN,1.5VOUT.

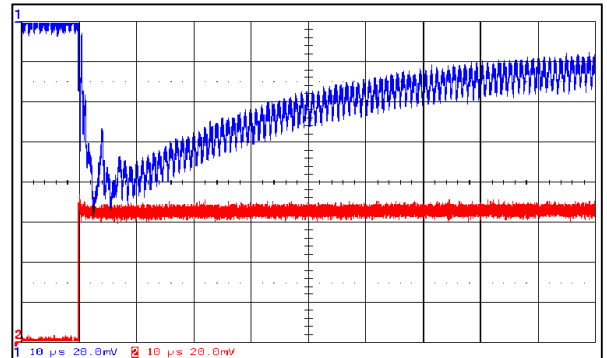

Blue(upper)=Vout 20mV/div Red(lower)=1A/div 10µs/div

Figure 42. Typical Transient response: 3.3VIN,2.5VOUT.

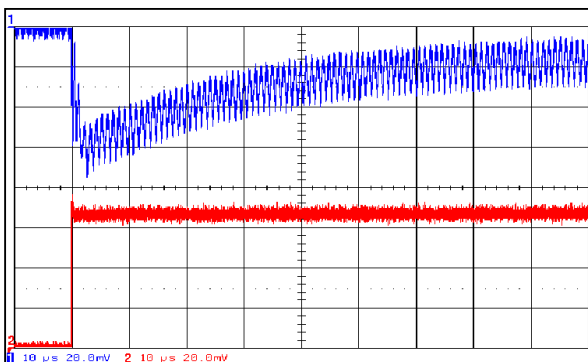

Blue(upper)=Vout 20mV/div Red(lower)=1A/div 10µs/div

Figure 40. Typical Transient response: 3.3VIN,1.8VOUT.

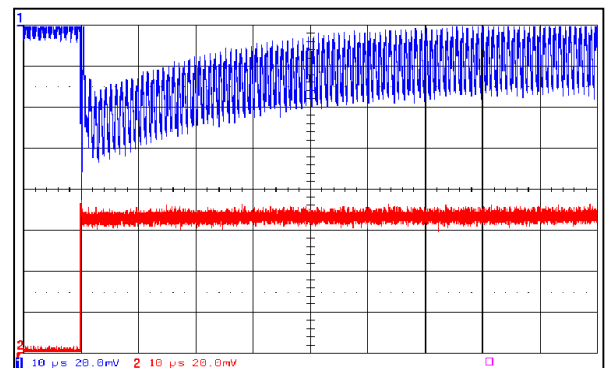

Blue(upper)=Vout 20mV/div Red(lower)=1A/div 10µs/div

Figure 43. Typical Transient response: 5.0VIN,1.5VOUT.

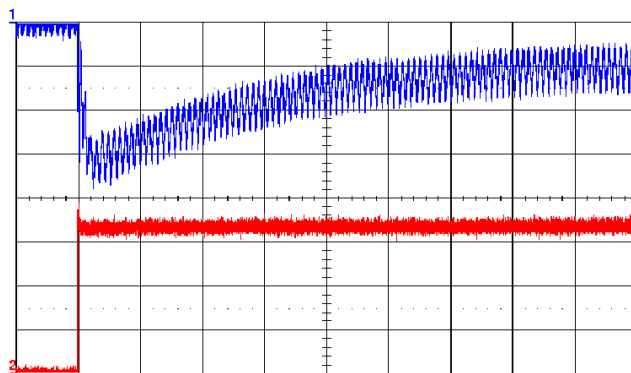

Blue(upper)=Vout 20mV/div Red(lower)=Vin1A/div 10µs/div

Figure 41. Typical Transient response: 3.3VIN,2.0VOUT.

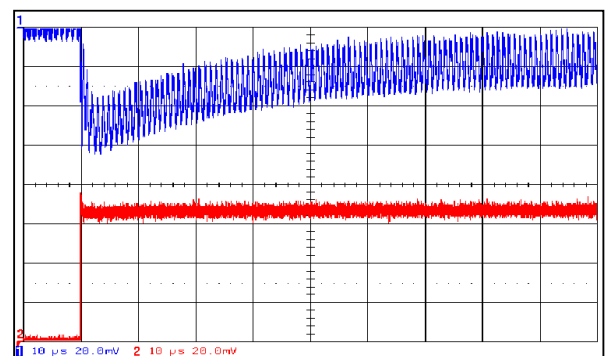

Blue(upper)=Vout 20mV/div Red(lower)=1A/div 10µs/div

Figure 44. Typical Transient response: 5.0VIN,1.8VOUT.

Characteristic Curves

The following figures provide typical Transient Response curves at room temperature ($T_A = 25\text{ }^\circ\text{C}$)

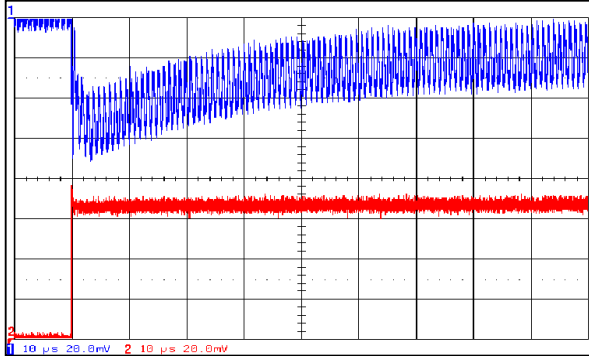

Blue(upper)=Vout 20mV/div Red(lower)=1A/div 10 μ s/div

Figure 45. Typical Transient response: 5.0VIN,2.0VOUT.

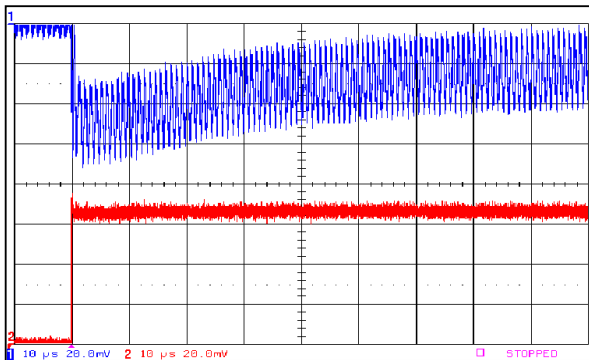

Blue(upper)=Vout 20mV/div Red(lower)=1A/div 10 μ s/div

Figure 46. Typical Transient response: 5.0VIN,2.5VOUT.

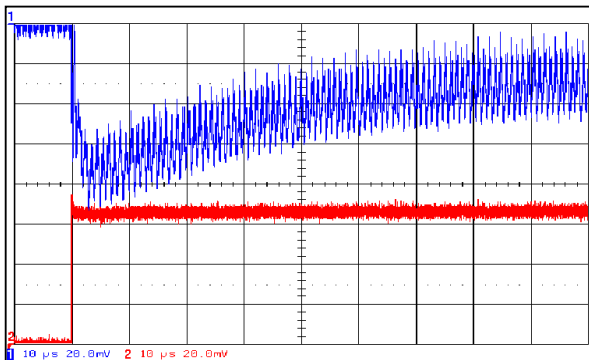

Blue(upper)=Vout 20mV/div Red(lower)=Vin 1A/div 10 μ s/div

Figure 47. Typical Transient response: 5.0VIN,3.3VOUT.

Characteristic Curves

The following figures provide typical derating characteristics curves .

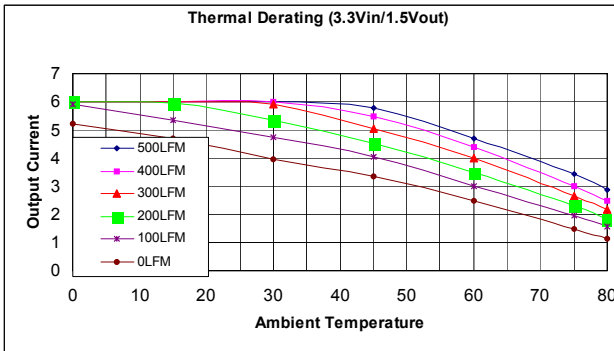

Figure 48. Thermal Derating for 3.3VIN ,1.5VOUT.

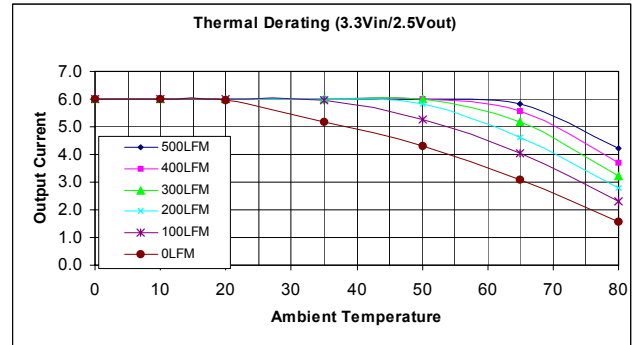

Figure 51. Thermal Derating for 3.3VIN ,2.5VOUT.

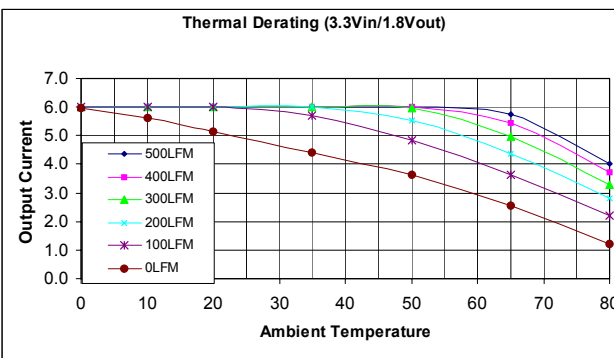

Figure 49. Thermal Derating for 3.3VIN ,1.8VOUT.

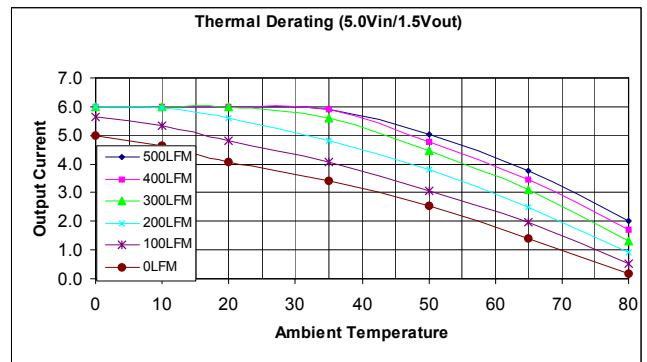

Figure 52. Thermal Derating for 5.0VIN ,1.5VOUT.

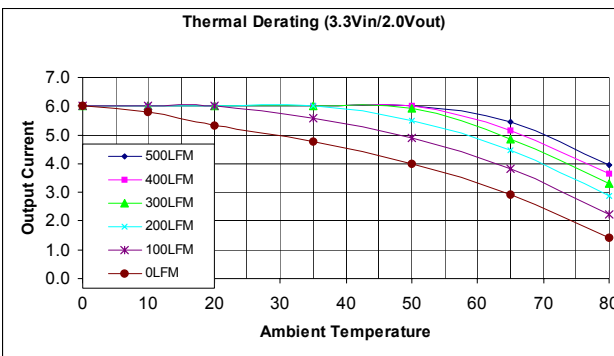

Figure 50. Thermal Derating for 3.3VIN ,2.0VOUT.

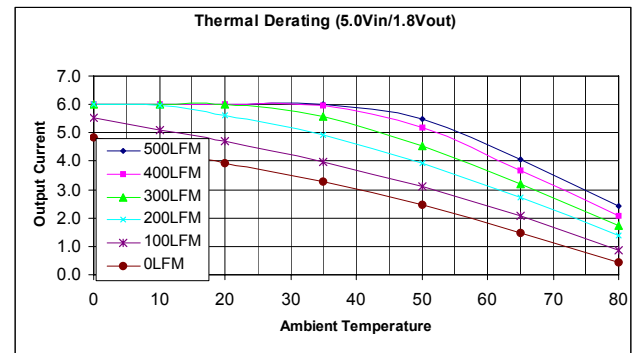

Figure 53. Thermal Derating for 5.0VIN ,1.8VOUT.

Characteristic Curves

The following figures provide typical Transient Response curves at room temperature ($T_A = 25\text{ }^\circ\text{C}$)

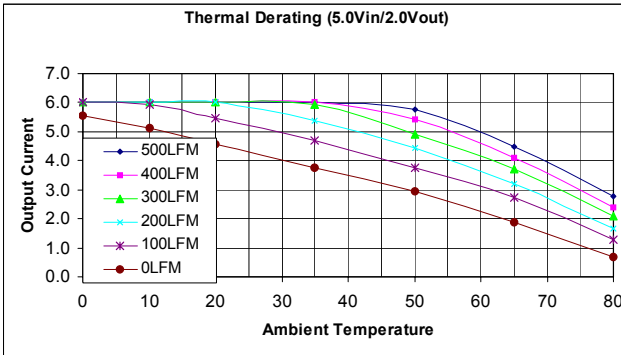

Figure 54. Thermal Derating for 5.0VIN ,2.0VOUT.

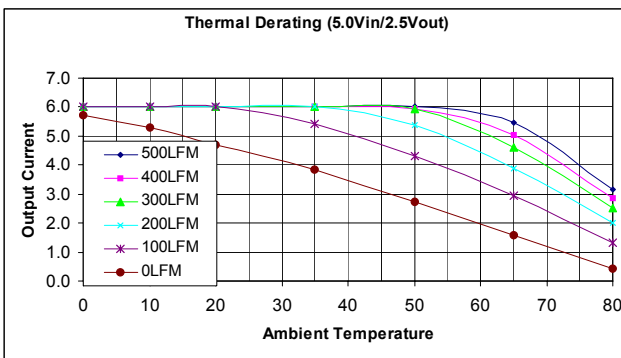

Figure 55. Thermal Derating for 5.0VIN ,2.5VOUT.

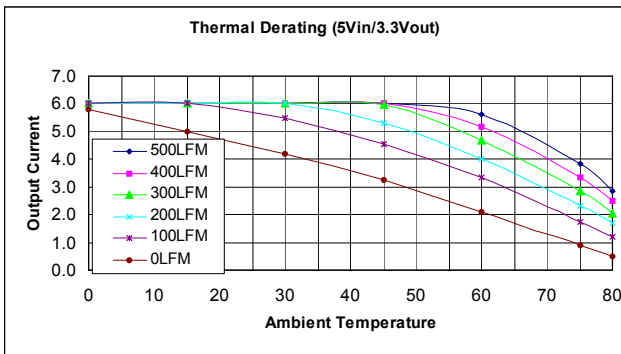

Figure 56. Thermal Derating for 5.0VIN ,3.3VOUT.

Test Configurations

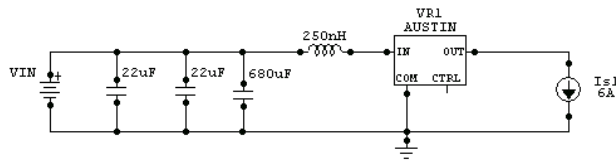

Figure 57. Input Reflected Ripple Current Test Setup.

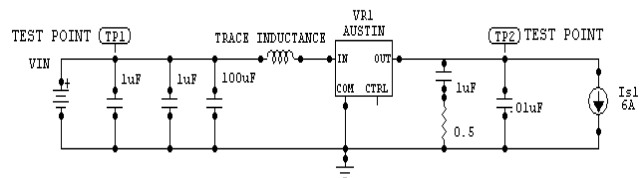

Figure 58. Input /Output Decoupling Circuit.

Design Considerations

Input Output Decoupling

An input capacitance of 100 mF, with an ESR of less than 100 milliohms, and at least 1 mF ceramic or equivalent is recommended for the input to the modules. The 100 mF should always be used unless main bulk buss capacitors are located close to the module. This capacitor provides decoupling in the event of a fault to the module output. Input voltage should never go below 2.5 volts or internal protection circuitry may fail to act. To achieve noise levels shown in Figures , one 100 mF tantalum capacitor and two 1 mF ceramic capacitors were used. 0.75 inches of 0.14 inch wide track (with no ground beneath) was used as an inductor between the input pin of the module and the decoupling capacitors (see Figure 1). An impedance vs. frequency plot has been provided for the 100 mF capacitor to aid in selecting equivalent parts.

Output decoupling used to achieve noise levels shown in Figures 2 — 11 was 1 mF in series with 0.5W and .01 mF. Ringing on the output due to common impedance with the input decoupling circuit was damped using the 1 mF/0.5W series combination. An equivalent damping network is recommended. Care should be taken that selected output decoupling capacitors do not form troublesome L-C resonant networks with track inductance. Austin Power Modules may be used with up to 10,000 mF of capacitance. the modules are designed to remain stable with any capacitor/ESR combination.

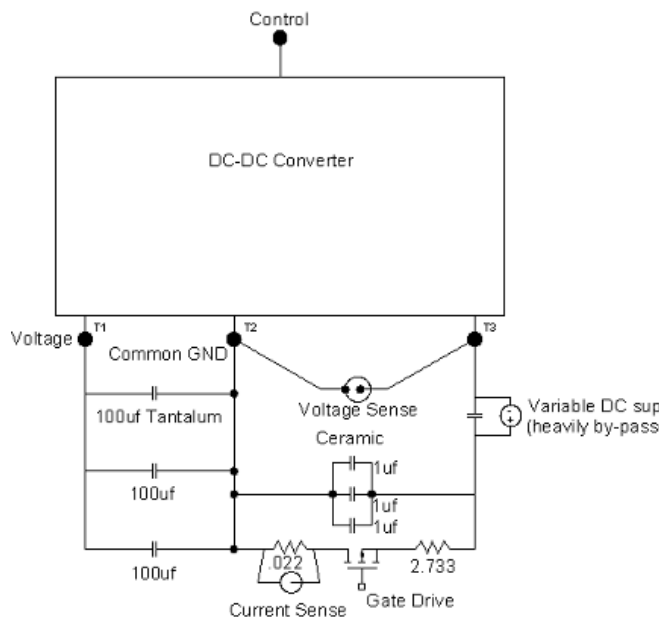

Figure 59. Load Transient Circuit.

Feature Descriptions

Output Regulation

These modules have intentional output resistance to facilitate improved transient response and paralleling. This means that the output voltage will decrease with increasing output current. For this reason, the total DC regulation window at a given operating and ambient temperature is comprised of a no load setpoint and a voltage drop due to module output resistance.

Output Overcurrent Protection/Overtemperature Protection

Current limiting is provided for momentary overloads and short circuits. A sustained overload may cause the thermal shutdown circuit to activate. The current limit inception is nominally 7 amperes with the power semiconductors at rated temperature in a 25 °C ambient environment. The thermal circuitry will shut down the module at 110 °C minimum on the power semiconductors' top surfaces measured using an infrared camera as described in the Thermal Ratings Section.

Output Control

The control pin is a dual-function port that serves to enable/disable the converter or provide a means of adjusting the output voltage over a prescribed range. When the control pin is grounded, the converter is disabled. With the pin left open, the converter regulates to its specified output voltage. For any other voltage applied to the pin, the output voltage follows this relationship:

$$V_{OUT} = \left(\frac{V_{CONTROL}}{1.5} \right) \bullet V_{OUTNOM}$$

The Thevenin equivalent input resistance of the control pin is approximately 7.68K ohms and the open circuit voltage is 1.5V.

The equation to margin low by connecting a resistor from the control pin to ground is:

$$R_{LOW} = 7.68K \left[\frac{V_{OUT}/V_{OUT\ nom}}{1 - V_{OUT}/V_{OUT\ nom}} \right]$$

To margin low by 5%, RLOW = 146K.

The equation to margin high by connecting a resistor, RHIGH, from the control pin to the input voltage, VIN is:

$$R_{HIGH} = \left[\frac{7.68K}{V_{OUT}/V_{OUT\ nom} - 1} \right] \left[\frac{V_{IN}}{1.5} - 1 \right] - 7.68K$$

To maintain high of 5%, RHIGH = 351K for VIN = 5 volts and RHIGH = 177K for VIN = 3.3 volts. Trim resistor tolerance will obviously affect output voltage. To determine the magni-

tude of this effect, simply use the extreme values in the above equations.

Because trimming affects the system reference, trimming beyond +/- 10% is unacceptable and +/- approximately 5% is desirable. One affect trimming has, aside from output voltage adjustment, is changing the current limit inception point. Trimming the unit down beyond 5% requires derating available current by 1% for every percent beyond 5 that the module is trimmed down. For example, if a module is trimmed down 7%, then output current would have to be derated 2%. If paralleled modules are to be trimmed using the control pin, divide the calculated trim resistance for a single unit by the number of modules paralleled. For example, if two paralleled units are to be trimmed 5% low, then a resistance of 146K divided by 2 should be used.

Parallel Operation

Up to five Austin Power Modules may be paralleled for extra output current needs. For N units operating in parallel, the output current rating will be equal to 6+(N-1)*4. For example, three modules can deliver 14 amps. For parallel operation, connect each control pin together. Care should be taken to make each module see the same approximate trace resistance to the load. In most cases, this requires that all converters be close together. Thermal derating can be approximated for parallel units by using the average current plus 1 amp for an individual module. For example, if three modules are carrying 12 amps, there is an average current of 3 amps so the derating curve at 4 amps would be used. Input and output decoupling should be scaled with the number of modules paralleled. If paralleled modules are to be trimmed using the control pin, divide the calculated trim resistance for a single unit by the number of modules paralleled. For example, if two paralleled units are to be trimmed 5% low, then a resistance of 146K divided by 2 should be used.

Thermal Considerations

Austin Power Modules are rated to operate in ambient temperatures from -40°C to 80°C . The derating curves below are provided as design aids for proper application of the power modules. To insure adequate cooling, the module temperature should be measured in the system configuration. Ideally, temperature will be measured using an infrared temperature probe (such as the FLUKE 80T-IR) or imaging system under the maximum ambient temperature and the minimum air flow conditions. Diode and FET case temperatures measured on the top surface's hottest spot should not exceed 105°C . An alternative method of measuring temperature is the use of thermocouples. For best results, a small thermocouple should be attached to the leads of each FET and diode using a small amount of cyanoacrylate adhesive.

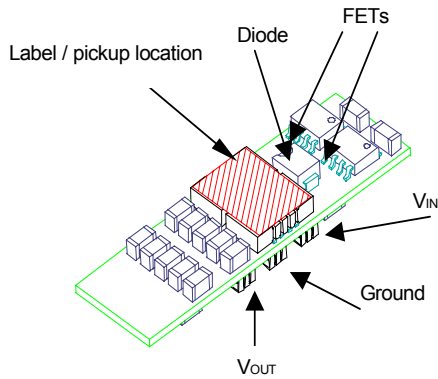

Figure 60. Temperature Measurement Location.

Surface Mount Information

Pick and Place Area

Although the module weight is minimized by using open-frame construction, the modules have a relatively large mass compared to conventional surface-mount components. To optimize the pick-and-place process, automated vacuum equipment variables such as nozzle size, tip style, vacuum pressure, and placement speed should be considered. The Product ID label si to be utilised for vacuum pick up of the Austin Power Module.

Tin Lead Soldering

The Austin Series SMT power modules are lead free modules and can be soldered either in a lead-free solder process or in a conventional Tin/Lead (Sn/Pb) process. It is recommended that the customer review data sheets in order to customize the solder reflow profile for each application board assembly. The following instructions must be observed when soldering these units. Failure to observe these instructions may result in the failure of or cause damage to the modules, and can adversely affect long-term reliability.

In a conventional Tin/Lead (Sn/Pb) solder process peak reflow temperatures are limited to less than 235°C. Typically, the eutectic solder melts at 183°C, wets the land, and subsequently wicks the device connection. Sufficient time must be allowed to fuse the plating on the connection to ensure a reliable solder joint. There are several types of SMT reflow technologies currently used in the industry. These surface mount power modules can be reliably soldered using natural forced convection, IR (radiant infrared), or a combination of convection/IR.

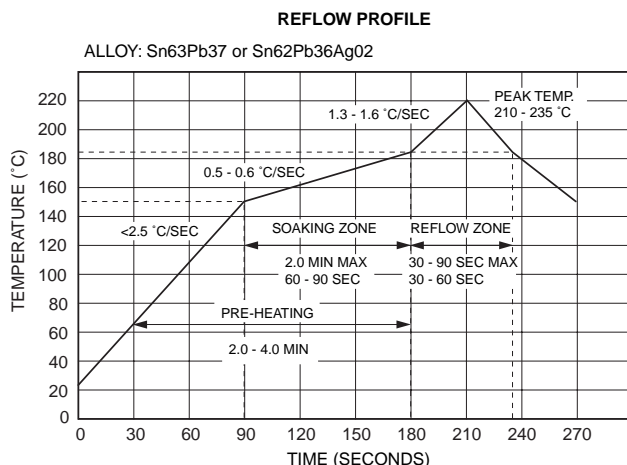

Figure 61. Reflow Profile.

An example of a reflow profile (using 63/37 solder) for the Austin Lynx™ SMT Power Module is:

- ▮ Pre-heating zone: room temperature to 183 °C (2.0 to 4.0 minutes maximum)
- ▮ Initial ramp rate: < 2.5 °C per second
- ▮ Soaking zone: 155 °C to 183 °C – 60 to 90 seconds typical (2.0 minutes maximum)
- ▮ Reflow zone ramp rate: 1.3 °C to 1.6 °C per second
- ▮ Reflow zone: 210 °C to 235 °C peak temperature – 30 to 60 seconds typical (90 seconds maximum)

Lead Free Soldering

The –Z version Austin Series SMT modules are lead-free (Pb-free) and RoHS compliant and are both forward and backward compatible in a Pb-free and a SnPb soldering process. Failure to observe the instructions below may result in the failure of or cause damage to the modules and can adversely affect long-term reliability.

Pb-free Reflow Profile

Power Systems will comply with J-STD-020 Rev. C (Moisture/Reflow Sensitivity Classification for Nonhermetic Solid State Surface Mount Devices) for both Pb-free solder profiles and MSL classification procedures. This standard provides a recommended forced-air-convection reflow profile based on the volume and thickness of the package (table 4-2). The suggested Pb-free solder paste is Sn/Ag/Cu (SAC). The recommended linear reflow profile using Sn/Ag/Cu solder is shown in Figure. 62.

MSL Rating

The Austin Series SMT modules have a MSL rating of 1.

Storage and Handling

The recommended storage environment and handling procedures for moisture-sensitive surface mount packages is detailed in J-STD-033 Rev. A (Handling, Packing, Shipping and Use of Moisture/Reflow Sensitive Surface Mount Devices). Moisture barrier bags (MBB) with desiccant are required for MSL ratings of 2 or greater. These sealed packages should not be broken until time of use. Once the original package is broken, the floor life of the product at conditions of £ 30°C and 60% relative humidity varies according to the MSL rating (see J-STD-033A). The shelf life for dry packed SMT packages will be a minimum of 12 months from the bag seal date, when stored at the following conditions: < 40° C, < 90% relative humidity.

Post Solder Cleaning and Drying Considerations

Post solder cleaning is usually the final circuit-board assembly process prior to electrical board testing. The result of inadequate cleaning and drying can affect both the reliability of a power module and the testability of the finished circuit-board assembly. For guidance on appropriate soldering, cleaning and drying procedures, refer to Lineage Power Board Mounted Power Modules: Soldering and Cleaning Application Note (AP01-056EPS).

Surface Mount Information (continued)

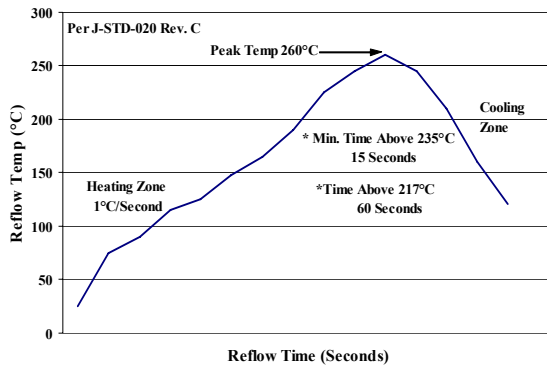

Figure 62. Recommended linear reflow profile using Sn/Ag/Cu solder.

Solder Ball and Cleanliness Requirements

The open frame (no case or potting) power module will meet the solder ball requirements per J-STD-001B. These requirements state that solder balls must neither be loose nor violate the power module minimum electrical spacing.

The cleanliness designator of the open frame power module is C00 (per J specification).

Surface-Mount Tape and Reel

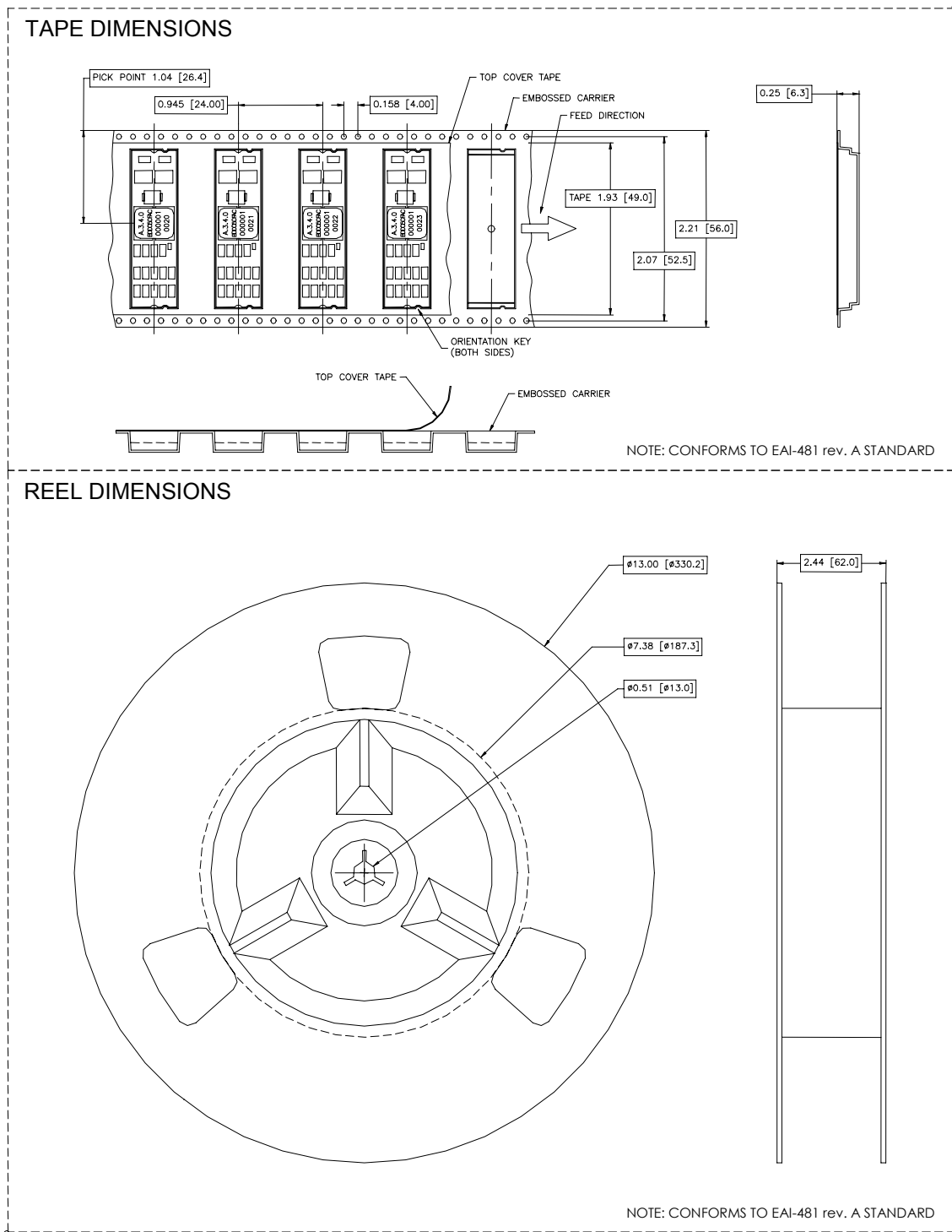

The above drawings represent Carrier Tape and Reel configuration. austin Power Modules are shipped in quantities of 250 modules per tape and reel, or four JEDEC trays with 42 modules per tray, for a total of 168 modules.

Austin Modules JEDEC tray

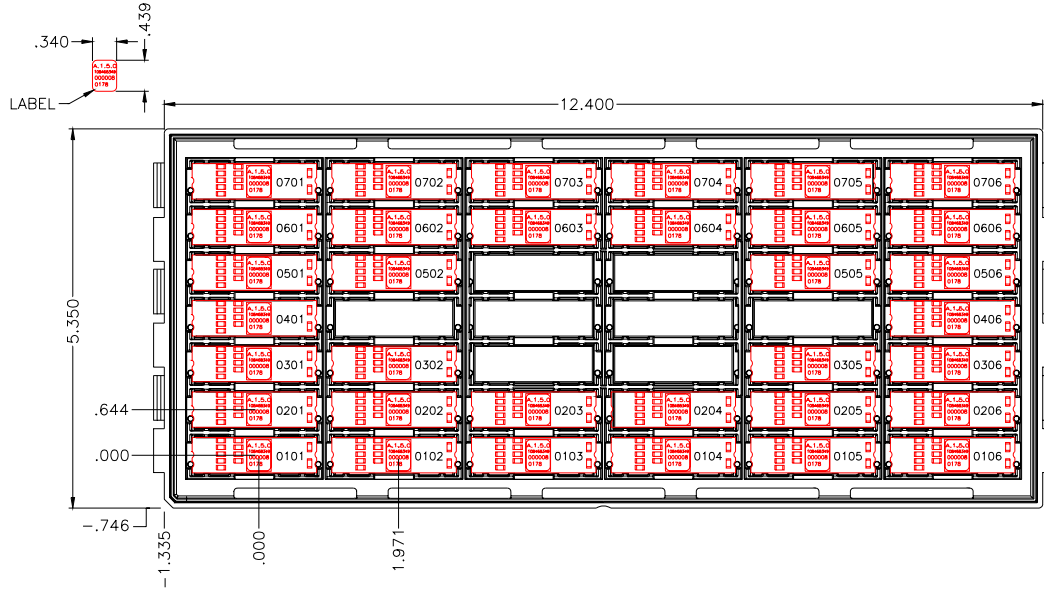

Mechanical Specification

Parameter	Symbol	Min	Typical	Max	Unit
Physical Size	L	—	*44.6 (1.756)	—	mm (in.)
*Dimensions listed are typical, with a tolerance of +/-0.01 inches	W	—	12.7 (0.5)	—	mm (in.)
	H	—	5.46 (0.215)	—	mm (in.)
	Weight	—	4.0	—	grams (oz.)
Module I/O, Connector Coplanarity	—	—	—	4 (.158)	mm (in.)
Interconnecting	Low-inductance surface-mount connector				
Shock	Method: MIL-STD-202F, method 213B, individual mounted units, 50 G, V2 sine, 6 ms; twice for each orthogonal axis				
Vibration	Method: TR-EOP-000063, Sec. 5.4.4, individual mounted units, 5 to 50 Hz sweep @ 0.5 G, 50 to 500 Hz sweep @ 1.5 G; vibration introduced in all 3 orthogonal axes				

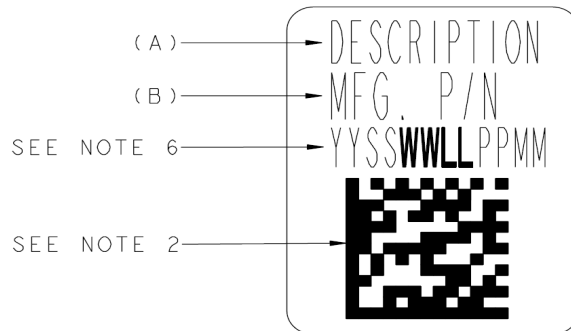
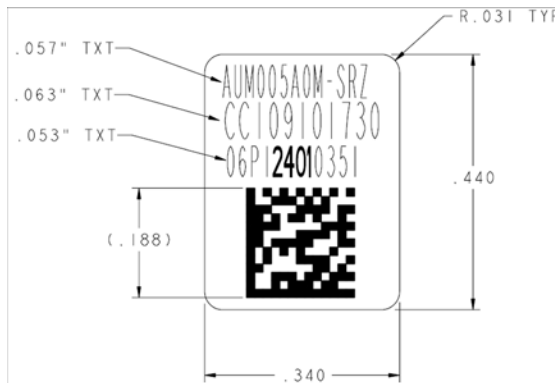

AN AUSTIN PRODUCT LABEL ILLUSTRATING AN AUM005A0M-SRZ, BUILT IN SLR SZ, MFGD DURING THE 04TH WEEK OF 2006 AT LOT 01, PANEL 03, MODULE 51.

GENERAL NOTES:

- (A) PRODUCT CODE: SEE CURRENT PDI CODE DESCRIPTION.
(B) MANUFACTURING P/N: SEE CURRENT PDI COMCODE NUMBER.
- THE BARCODE SHALL BE PLACED ON THIS LABEL APPROXIMATELY AS SHOWN. BARCODING REPRESENTS MANUFACTURING DATE CODE AND SERIAL NUMBER IF SERIAL NUMBER IS REQUIRED. BARCODE IS 2D DOT MATRIX SYMBOLOGY.
- UNLESS OTHERWISE SPECIFIED, ALL DIMENSIONS ARE IN INCHES. NON-LIMITED DIMENSIONS, OTHER THAN SIZE OF RAW MATERIAL SHALL BE HELD AS FOLLOWS WHEN EXPRESSED:
TO 2 DECIMAL PLACES ±.01
TO 3 DECIMAL PLACES ±.005
AS ANGLES ±5°
- DIMENSIONS IN () ARE FOR REFERENCE ONLY.
- SEE CURRENT STOCK LIST FOR BLANK LABEL COMCODE. A UL APPROVED MARKING SYSTEM MUST BE USED. FOR APPROVED RIBBON INKS AND THERMAL PRINTERS, SEE MATRIX VAULTED DOCUMENT: "SAFETY_AGENCY_INFORMATION_for_Labels."
- THE MANUFACTURING DATE CODE IS A SIX (6) CHARACTER DESIGNATION [YYSSWW] THAT STANDS FOR YEAR LOCATION WEEK. YY IS THE LAST TWO DIGITS OF THE YEAR. SS [MANUFACTURING LOCATION CODE] IS AS SPECIFIED IN MPS176192. WW IS THE FISCAL WEEK PLUS 20 [E.G. JAN 01 WEEK IS 21] AS SPECIFIED IN KS-23938. THE SERIAL NUMBER IS A SIX (6) DIGIT NUMBER [LLPPMM]. THE SERIAL NUMBER IS DEFINED AS FOLLOWS: LL IS LOT NUMBER, PP IS PANEL NUMBER (01-99), MM IS MODULE NUMBER (01-78). [I.E. YYSSWWLLPPMM]. CHARACTERS "WWLL" TO BE IN BOLD FONT.
- ROHS COMPLIANT PRODUCT CODES CONTAIN THE LETTER "Z" AT THE END OF THE PRODUCT CODE DESCRIPTION, LABEL CHARACTERS AND LINES TO BE GREEN ON A WHITE BACKGROUND. LOCATE SYMBOLS AND CHARACTERS APPROXIMATELY AS SHOWN.

Figure 63. Detailed Drawing of Product ID Label.

Outline Diagram

Dimensions are in millimeters and (inches).

Tolerances: x.x mm \pm 0.5 mm (x.xx in. \pm 0.02 in.) [unless otherwise indicated]
x.xx mm \pm 0.25 mm (x.xxx in. \pm 0.010 in.)

Top View

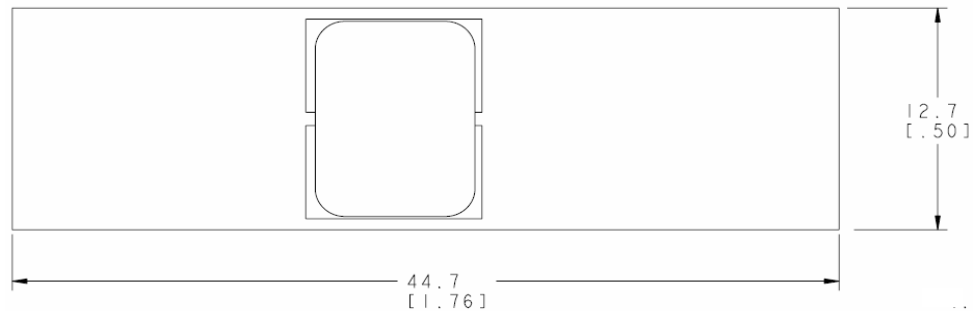

Side View

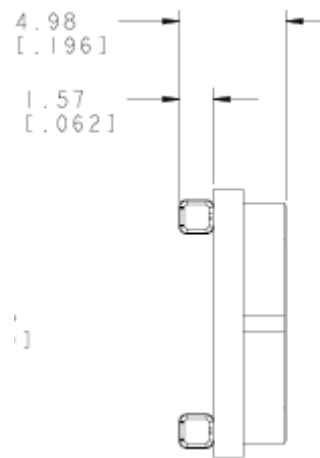

Bottom View

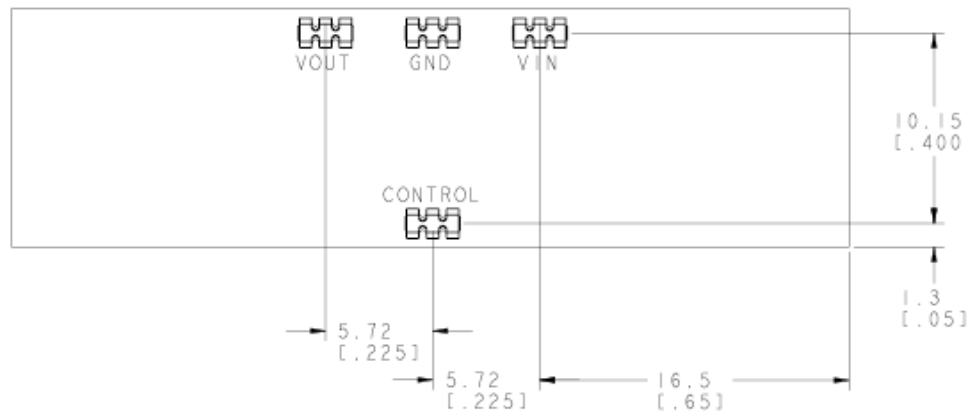

Recommended Pad Layout

Component-side footprint.

Dimensions are in millimeters and (inches).

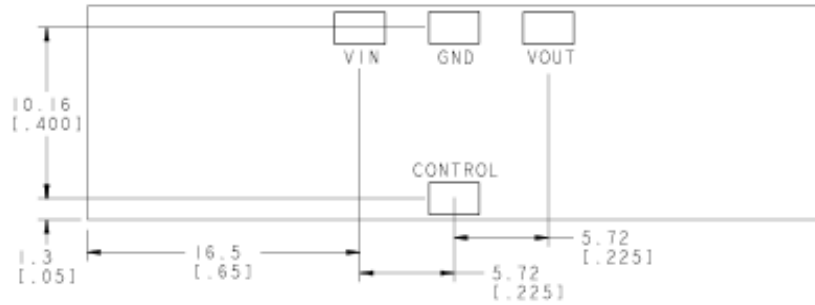

Ordering Information

Please contact your Lineage Power Sales Representative for pricing, availability and optional features.

Leaded Product Code	Leaded Comcode	Expanded Product Description
AUSTIN 5V 3.3V 5A T	108612961	5 VIN; 3.3 VOUT; 4 terminal surface mount; 5A IOU; 300 A/msec transient response; Tape & Reel package
AUSTIN 5V 2.5V 5A T	108612953	5 VIN; 2.5 VOUT; 4 terminal surface mount; 5A IOU; 300 A/msec transient response; Tape & Reel package
AUSTIN 5V 2.0V 5A T	108612946	5 VIN; 2.0 VOUT; 4 terminal surface mount; 5A IOU; 300 A/msec transient response; Tape & Reel package
AUSTIN 5V 1.8V 5A T	108612938	5 VIN; 1.8 VOUT; 4 terminal surface mount; 5A IOU; 300 A/msec transient response; Tape & Reel package
AUSTIN 5V 1.5V 5A T	108613266	5 VIN; 1.5 VOUT; 4 terminal surface mount; 5A IOU; 300 A/msec transient response; Tape & Reel package
AUSTIN 3.3V 2.5V 5A T	108612912	3.3 VIN; 2.5 VOUT; 4 terminal surface mount; 5A IOU; 300 A/msec transient response; Tape & Reel package
AUSTIN 3.3V 2.0V 5A T	108613258	3.3 VIN; 2.0 VOUT; 4 terminal surface mount; 5A IOU; 300 A/msec transient response; Tape & Reel package
AUSTIN 3.3V 1.8V 5A T	108612920	3.3 VIN; 1.8 VOUT; 4 terminal surface mount; 5A IOU; 300 A/msec transient response; Tape & Reel package
AUSTIN 3.3V 1.5V 5A T	108613241	3.3 VIN; 1.5 VOUT; 4 terminal surface mount; 5A IOU; 300 A/msec transient response; Tape & Reel package
AUSTIN 5V 3.3V 5A J	108505710	5 VIN; 3.3 VOUT; 4 terminal surface mount; 5A IOU; 300 A/msec transient response; JEDEC Tray package
AUSTIN 5V 2.5V 5A J	108505702	5 VIN; 2.5 VOUT; 4 terminal surface mount; 5A IOU; 300 A/msec transient response; JEDEC Tray package
AUSTIN 5V 2.0V 5A J	108505694	5 VIN; 2.0 VOUT; 4 terminal surface mount; 5A IOU; 300 A/msec transient response; JEDEC Tray package
AUSTIN 5V 1.8V 5A J	108505686	5 VIN; 1.8 VOUT; 4 terminal surface mount; 5A IOU; 300 A/msec transient response; JEDEC Tray package
AUSTIN 5V 1.5V 5A J	108505678	5 VIN; 1.5 VOUT; 4 terminal surface mount; 5A IOU; 300 A/msec transient response; JEDEC Tray package
AUSTIN 3.3V 2.5V 5A J	108468372	3.3 VIN; 2.5 VOUT; 4 terminal surface mount; 5A IOU; 300 A/msec transient response; JEDEC Tray package
AUSTIN 3.3V 2.0V 5A J	108468364	3.3 VIN; 2.0 VOUT; 4 terminal surface mount; 5A IOU; 300 A/msec transient response; JEDEC Tray package
AUSTIN 3.3V 1.8V 5A J	108468356	3.3 VIN; 1.8 VOUT; 4 terminal surface mount; 5A IOU; 300 A/msec transient response; JEDEC Tray package
AUSTIN 3.3V 1.5V 5A J	108468349	3.3 VIN; 1.5 VOUT; 4 terminal surface mount; 5A IOU; 300 A/msec transient response; JEDEC Tray package

Ordering Information (continued)

Lead-Free Product code	Lead-Free Comcode	Expanded Product Description
AUH005A0F-SRZ	CC109101607	5 VIN; 3.3 VOUT; 4 terminal surface mount; 5A IOUT; 300 A/msec transient response; Tape & Reel package
AUH005A0G-SRZ	CC109101623	5 VIN; 2.5 VOUT; 4 terminal surface mount; 5A IOUT; 300 A/msec transient response; Tape & Reel package
AUH005A0D-SRZ	CC109101581	5 VIN; 2.0 VOUT; 4 terminal surface mount; 5A IOUT; 300 A/msec transient response; Tape & Reel package
AUH005A0Y-SRZ	CC109101672	5 VIN; 1.8 VOUT; 4 terminal surface mount; 5A IOUT; 300 A/msec transient response; Tape & Reel package
AUH005A0M-SRZ	CC109101648	5 VIN; 1.5 VOUT; 4 terminal surface mount; 5A IOUT; 300 A/msec transient response; Tape & Reel package
AUM005A0G-SRZ	CC109101714	3.3 VIN; 2.5 VOUT; 4 terminal surface mount; 5A IOUT; 300 A/msec transient response; Tape & Reel package
AUM005A0D-SRZ	CC109101697	3.3 VIN; 2.0 VOUT; 4 terminal surface mount; 5A IOUT; 300 A/msec transient response; Tape & Reel package
AUM005A0Y-SRZ	CC109101755	3.3 VIN; 1.8 VOUT; 4 terminal surface mount; 5A IOUT; 300 A/msec transient response; Tape & Reel package
AUM005A0M-SRZ	CC109101730	3.3 VIN; 1.5 VOUT; 4 terminal surface mount; 5A IOUT; 300 A/msec transient response; Tape & Reel package
AUH005A0F-SJZ	CC109101598	5 VIN; 3.3 VOUT; 4 terminal surface mount; 5A IOUT; 300 A/msec transient response; JEDEC Tray package
AUH005A0G-SJZ	CC109101615	5 VIN; 2.5 VOUT; 4 terminal surface mount; 5A IOUT; 300 A/msec transient response; JEDEC Tray package
AUH005A0D-SJZ	CC109101573	5 VIN; 2.0 VOUT; 4 terminal surface mount; 5A IOUT; 300 A/msec transient response; JEDEC Tray package
AUH005A0Y-SJZ	CC109101656	5 VIN; 1.8 VOUT; 4 terminal surface mount; 5A IOUT; 300 A/msec transient response; JEDEC Tray package
AUH005A0M-SJZ	CC109101631	5 VIN; 1.5 VOUT; 4 terminal surface mount; 5A IOUT; 300 A/msec transient response; JEDEC Tray package
AUM005A0G-SJZ	CC109101706	3.3 VIN; 2.5 VOUT; 4 terminal surface mount; 5A IOUT; 300 A/msec transient response; JEDEC Tray package
AUM005A0D-SJZ	CC109101680	3.3 VIN; 2.0 VOUT; 4 terminal surface mount; 5A IOUT; 300 A/msec transient response; JEDEC Tray package
AUM005A0Y-SJZ	CC109101747	3.3 VIN; 1.8 VOUT; 4 terminal surface mount; 5A IOUT; 300 A/msec transient response; JEDEC Tray package
AUM005A0M-SJZ	CC109101722	3.3 VIN; 1.5 VOUT; 4 terminal surface mount; 5A IOUT; 300 A/msec transient response; JEDEC Tray package

-Z refers to RoHS compliant versions.



World Wide Headquarters
Lineage Power Corporation
 30 00 Skyline Drive, Mesquite, TX 75149, U S A
+1-800-526-7819
 (Outside U.S.A.: +1-972-284-2626)
www.lineagepower.com
e-mail: techsupport1@lineagepower.com

Asia-Pacific Headquarters
 Tel: +65 6416 4283

Europe, Middle-East and Africa Headquarters
 Tel: +49 89 6089 286

India Headquarters
 Tel: +91 80 28411633

Lineage Power reserves the right to make changes to the product(s) or information contained herein without notice. No liability is assumed as a result of their use or application. No rights under any patent accompany the sale of any such product(s) or information.

© 2008 Lineage Power Corporation, (Mesquite, Texas) All International Rights Reserved.